

YXG SERIES

105°C Low Impedance

•Load Life : 105°C 3000~6000 hours.



◆SPECIFICATIONS

Items	Characteristics																														
Category Temperature Range	-40~+105°C																														
Rated Voltage Range	6.3~100Vdc																														
Capacitance Tolerance	±20% (20°C, 120Hz)																														
Leakage Current(MAX)	I=0.01CV or 3µA whichever is greater.(After 2 minutes) I=Leakage Current(µA) C=Capacitance(µF) V=Rated Voltage(Vdc)																														
Dissipation Factor(MAX) (tanδ)	<table border="1"> <tr> <td>Rated Voltage (Vdc)</td> <td>6.3</td> <td>10</td> <td>16</td> <td>25</td> <td>35</td> <td>50</td> <td>63</td> <td>100</td> <td>(20°C, 120Hz)</td> </tr> <tr> <td>tanδ</td> <td>0.22</td> <td>0.19</td> <td>0.16</td> <td>0.14</td> <td>0.12</td> <td>0.10</td> <td>0.09</td> <td>0.08</td> <td></td> </tr> </table> <p>When capacitance is over 1000µF, tanδ shall be added 0.02 to the listed value with increase of every 1000µF.</p>	Rated Voltage (Vdc)	6.3	10	16	25	35	50	63	100	(20°C, 120Hz)	tanδ	0.22	0.19	0.16	0.14	0.12	0.10	0.09	0.08											
Rated Voltage (Vdc)	6.3	10	16	25	35	50	63	100	(20°C, 120Hz)																						
tanδ	0.22	0.19	0.16	0.14	0.12	0.10	0.09	0.08																							
Endurance	<p>After applying rated voltage with rated ripple current for specified time at 105°C, the capacitors shall meet the following requirements.</p> <table border="1"> <tr> <td>Capacitance Change</td> <td>Within ±25% of the initial value.</td> <td>Case Size</td> <td>Life Time (hrs)</td> </tr> <tr> <td>Dissipation Factor</td> <td>Not more than 200% of the specified value.</td> <td>φD≤6.3</td> <td>3000</td> </tr> <tr> <td>Leakage Current</td> <td>Not more than the specified value.</td> <td>φD=8</td> <td>4000</td> </tr> <tr> <td></td> <td></td> <td>φD=10</td> <td>5000</td> </tr> <tr> <td></td> <td></td> <td>φD≥12.5</td> <td>6000</td> </tr> </table>	Capacitance Change	Within ±25% of the initial value.	Case Size	Life Time (hrs)	Dissipation Factor	Not more than 200% of the specified value.	φD≤6.3	3000	Leakage Current	Not more than the specified value.	φD=8	4000			φD=10	5000			φD≥12.5	6000										
Capacitance Change	Within ±25% of the initial value.	Case Size	Life Time (hrs)																												
Dissipation Factor	Not more than 200% of the specified value.	φD≤6.3	3000																												
Leakage Current	Not more than the specified value.	φD=8	4000																												
		φD=10	5000																												
		φD≥12.5	6000																												
Low Temperature Stability Impedance Ratio(MAX)	<table border="1"> <tr> <td>Rated Voltage (Vdc)</td> <td>6.3</td> <td>10</td> <td>16</td> <td>25</td> <td>35</td> <td>50</td> <td>63</td> <td>100</td> <td>(120Hz)</td> </tr> <tr> <td>Z(-25°C)/Z(20°C)</td> <td>4</td> <td>3</td> <td>2</td> <td>2</td> <td>2</td> <td>2</td> <td>2</td> <td>2</td> <td></td> </tr> <tr> <td>Z(-40°C)/Z(20°C)</td> <td>8</td> <td>6</td> <td>4</td> <td>3</td> <td>3</td> <td>3</td> <td>3</td> <td>3</td> <td></td> </tr> </table>	Rated Voltage (Vdc)	6.3	10	16	25	35	50	63	100	(120Hz)	Z(-25°C)/Z(20°C)	4	3	2	2	2	2	2	2		Z(-40°C)/Z(20°C)	8	6	4	3	3	3	3	3	
Rated Voltage (Vdc)	6.3	10	16	25	35	50	63	100	(120Hz)																						
Z(-25°C)/Z(20°C)	4	3	2	2	2	2	2	2																							
Z(-40°C)/Z(20°C)	8	6	4	3	3	3	3	3																							

◆MULTIPLIER FOR RIPPLE CURRENT

Frequency (Hz)		120	1k	10k	100k≤
Coefficient	6.8~33µF	0.42	0.70	0.90	1.00
	39~270µF	0.50	0.73	0.92	1.00
	330~680µF	0.55	0.77	0.94	1.00
	820~1800µF	0.60	0.80	0.96	1.00
	2200~18000µF	0.70	0.85	0.98	1.00

◆DIMENSIONS

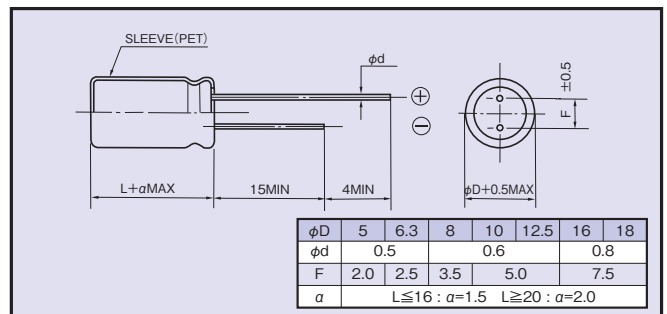

◆PART NUMBER

□□□ Rated Voltage YXG Series □□□□□ Capacitance M Capacitance Tolerance □□□ Option □□ Lead Forming DxL Case Size

◆OPTION

PET Sleeve	Code
	EFC

◆STANDARD SIZE

Rated Voltage (Vdc)	Capacitance (μF)	Size φD×L(mm)	Rated ripple current (mA r.m.s./105°C, 100kHz)	Impedance (Ω MAX)	
				20°C, 100kHz	-10°C, 100kHz
6.3	150	5×11	210	0.58	2.3
	330	6.3×11	340	0.22	0.87
	680	8×11.5	640	0.13	0.52
	820	10×12.5	865	0.080	0.32
	1000	8×16	840	0.087	0.35
	1200	8×20	1050	0.069	0.27
	1200	10×16	1210	0.060	0.24
	1500	10×20	1400	0.046	0.18
	1800	12.5×16	1450	0.049	0.16
	2200	10×23	1650	0.042	0.17
	2700	10×28	1910	0.031	0.12
	2700	16×16	1940	0.042	0.12
	3300	12.5×20	1900	0.035	0.12
	3900	12.5×25	2230	0.027	0.089
	3900	18×16	2210	0.043	0.11
	4700	12.5×30	2650	0.024	0.078
	5600	12.5×35	2880	0.020	0.065
	5600	16×20	2530	0.027	0.078
	6800	12.5×40	3350	0.017	0.056
	6800	16×25	2930	0.021	0.060
6800	18×20	2860	0.026	0.067	
8200	16×31.5	3450	0.017	0.050	
10000	16×35.5	3610	0.015	0.044	
10000	18×25	3140	0.019	0.049	
12000	16×40	4080	0.013	0.038	
12000	18×31.5	4170	0.015	0.040	
15000	18×35.5	4220	0.014	0.038	
18000	18×40	4280	0.012	0.032	
10	100	5×11	210	0.58	2.3
	220	6.3×11	340	0.22	0.87
	470	8×11.5	640	0.13	0.52
	680	8×16	840	0.087	0.35
	680	10×12.5	865	0.080	0.32
	1000	8×20	1050	0.069	0.27
	1000	10×16	1210	0.060	0.24
	1200	10×20	1400	0.046	0.18
	1500	10×23	1650	0.042	0.17
	1500	12.5×16	1450	0.049	0.16
	2200	10×28	1910	0.031	0.12
	2200	12.5×20	1900	0.035	0.12
	2200	16×16	1940	0.042	0.12
	2700	18×16	2210	0.043	0.11
	3300	12.5×25	2230	0.027	0.089
	3900	12.5×30	2650	0.024	0.078
	3900	16×20	2530	0.027	0.078
	4700	12.5×35	2880	0.020	0.065
	5600	12.5×40	3350	0.017	0.056
	5600	16×25	2930	0.021	0.060
5600	18×20	2860	0.026	0.067	
6800	16×31.5	3450	0.017	0.050	
6800	18×25	3140	0.019	0.049	
8200	16×35.5	3610	0.015	0.044	
8200	18×31.5	4170	0.015	0.040	
10000	16×40	4080	0.013	0.038	
10000	18×35.5	4220	0.014	0.038	
12000	18×40	4280	0.012	0.032	

Rated Voltage (Vdc)	Capacitance (μF)	Size φD×L(mm)	Rated ripple current (mA r.m.s./105°C, 100kHz)	Impedance (Ω MAX)	
				20°C, 100kHz	-10°C, 100kHz
16	56	5×11	210	0.58	2.3
	120	6.3×11	340	0.22	0.87
	330	8×11.5	640	0.13	0.52
	470	8×16	840	0.087	0.35
	470	10×12.5	865	0.080	0.32
	680	8×20	1050	0.069	0.27
	680	10×16	1210	0.060	0.24
	1000	10×20	1400	0.046	0.18
	1000	12.5×16	1450	0.049	0.16
	1200	10×23	1650	0.042	0.17
	1500	10×28	1910	0.031	0.12
	1500	12.5×20	1900	0.035	0.12
	1500	16×16	1940	0.042	0.12
	2200	12.5×25	2230	0.027	0.089
	2200	18×16	2210	0.043	0.11
	2700	12.5×30	2650	0.024	0.078
	2700	16×20	2530	0.027	0.078
	3300	12.5×35	2880	0.020	0.065
	3900	12.5×40	3350	0.017	0.056
	3900	16×25	2930	0.021	0.060
3900	18×20	2860	0.026	0.067	
4700	16×31.5	3450	0.017	0.050	
4700	18×25	3140	0.019	0.049	
5600	16×35.5	3610	0.015	0.044	
5600	18×31.5	4170	0.015	0.040	
6800	16×40	4080	0.013	0.038	
8200	18×35.5	4220	0.014	0.038	
10000	18×40	4280	0.012	0.032	
25	47	5×11	210	0.58	2.3
	100	6.3×11	340	0.22	0.87
	220	8×11.5	640	0.13	0.52
	330	8×16	840	0.087	0.35
	330	10×12.5	865	0.080	0.32
	470	8×20	1050	0.069	0.27
	470	10×12.5	1700	0.053	0.16
	470	10×16	1210	0.060	0.24
	680	10×20	1400	0.046	0.18
	680	12.5×16	1450	0.049	0.16
	820	10×23	1650	0.042	0.17
	1000	10×28	1910	0.031	0.12
	1000	12.5×20	1900	0.035	0.12
	1000	16×16	1940	0.042	0.12
	1200	18×16	2210	0.043	0.11
	1500	12.5×25	2230	0.027	0.089
	1800	12.5×30	2650	0.024	0.078
	1800	16×20	2530	0.027	0.078
	2200	12.5×35	2880	0.020	0.065
	2200	18×20	2860	0.026	0.067
2700	12.5×40	3350	0.017	0.056	
2700	16×25	2930	0.021	0.060	
3300	16×31.5	3450	0.017	0.050	
3300	18×25	3140	0.019	0.049	
3900	16×35.5	3610	0.015	0.044	
3900	18×31.5	4170	0.015	0.040	
4700	16×40	4080	0.013	0.038	
4700	18×35.5	4220	0.014	0.038	
5600	18×40	4280	0.012	0.032	

◆STANDARD SIZE

Rated Voltage (Vdc)	Capacitance (μF)	Size φD×L(mm)	Rated ripple current (mA r.m.s./105°C, 100kHz)	Impedance (Ω MAX)		Rated Voltage (Vdc)	Capacitance (μF)	Size φD×L(mm)	Rated ripple current (mA r.m.s./105°C, 100kHz)	Impedance (Ω MAX)	
				20°C, 100kHz	-10°C, 100kHz					20°C, 100kHz	-10°C, 100kHz
35	33	5×11	210	0.58	2.3	63	15	5×11	55	2.3	9.3
	56	6.3×11	340	0.22	0.87		33	6.3×11	115	1.2	5.0
	150	8×11.5	640	0.13	0.52		56	8×11.5	232	0.63	2.8
	220	8×16	840	0.087	0.35		82	8×16	300	0.45	2.1
	220	10×12.5	865	0.080	0.32		82	10×12.5	288	0.43	1.8
	270	8×20	1050	0.069	0.27		120	8×20	362	0.33	1.6
	330	10×16	1210	0.060	0.24		120	10×16	357	0.31	1.5
	470	10×20	1400	0.046	0.18		180	10×20	466	0.21	0.94
	470	12.5×16	1450	0.049	0.16		180	12.5×16	466	0.23	1.1
	560	10×23	1650	0.042	0.17		220	10×23	531	0.20	0.84
	680	10×28	1910	0.031	0.12		270	10×28	663	0.15	0.71
	680	12.5×20	1900	0.035	0.12		270	12.5×20	690	0.16	0.64
	680	16×16	1940	0.042	0.12		270	16×16	795	0.14	0.66
	1000	12.5×25	2230	0.027	0.089		330	12.5×25	784	0.12	0.45
	1000	18×16	2210	0.043	0.11		390	18×16	920	0.12	0.50
	1200	12.5×30	2650	0.024	0.078		470	12.5×30	905	0.10	0.42
	1200	16×20	2530	0.027	0.078		470	16×20	1040	0.091	0.38
	1500	12.5×35	2880	0.020	0.065		560	12.5×35	1050	0.083	0.35
	1800	12.5×40	3350	0.017	0.056		560	16×25	1250	0.073	0.27
	1800	16×25	2930	0.021	0.060		680	12.5×40	1180	0.071	0.30
	1800	18×20	2860	0.026	0.067		680	18×20	1240	0.080	0.30
2200	16×31.5	3450	0.017	0.050	820	16×31.5	1570	0.054	0.20		
2200	18×25	3140	0.019	0.049	820	18×25	1490	0.057	0.21		
2700	16×35.5	3610	0.015	0.044	1000	16×35.5	1790	0.045	0.17		
2700	18×31.5	4170	0.015	0.040	1000	18×31.5	1630	0.047	0.17		
3300	16×40	4080	0.013	0.038	1200	16×40	2020	0.040	0.15		
3300	18×35.5	4220	0.014	0.038	1200	18×35.5	1790	0.040	0.15		
3900	18×40	4280	0.012	0.032	1500	18×40	2330	0.036	0.13		
50	22	5×11	180	0.70	2.8	100	6.8	5×11	55	2.3	9.3
	56	6.3×11	295	0.30	1.2		15	6.3×11	115	1.2	5.0
	100	8×11.5	555	0.17	0.68		27	8×11.5	232	0.63	2.8
	120	8×16	730	0.12	0.48		39	8×16	300	0.45	2.1
	150	10×12.5	760	0.12	0.48		47	10×12.5	288	0.43	1.8
	150	10×12.5	1280	0.073	0.22		56	8×20	362	0.33	1.6
	180	8×20	910	0.091	0.36		56	10×12.5	1000	0.17	0.66
	220	10×16	1050	0.084	0.34		68	10×16	357	0.31	1.5
	270	10×20	1220	0.060	0.24		82	10×20	466	0.21	0.94
	270	12.5×16	1260	0.061	0.20		82	12.5×16	466	0.23	1.1
	330	10×23	1440	0.055	0.22		100	10×23	531	0.20	0.84
	470	10×28	1690	0.043	0.17		120	10×28	663	0.15	0.71
	470	12.5×20	1660	0.045	0.15		120	12.5×20	690	0.16	0.64
	470	16×16	1690	0.055	0.17		150	16×16	795	0.14	0.66
	560	12.5×25	1950	0.034	0.11		180	12.5×25	784	0.12	0.45
	560	18×16	1930	0.054	0.15		180	18×16	920	0.12	0.50
	680	12.5×30	2310	0.030	0.10		220	12.5×30	905	0.10	0.42
	820	12.5×35	2510	0.025	0.083		220	16×20	1040	0.091	0.38
	820	16×20	2210	0.034	0.10		270	12.5×35	1050	0.083	0.35
	1000	12.5×40	2920	0.021	0.069		270	16×25	1250	0.073	0.27
	1000	16×25	2555	0.025	0.075		330	12.5×40	1180	0.071	0.30
1000	18×20	2490	0.036	0.097	330	18×20	1240	0.080	0.30		
1200	16×31.5	3010	0.022	0.066	390	16×31.5	1570	0.054	0.20		
1200	18×25	2740	0.026	0.070	390	18×25	1490	0.057	0.21		
1500	16×35.5	3150	0.019	0.057	470	16×35.5	1790	0.045	0.17		
1800	16×40	3710	0.016	0.048	470	18×31.5	1630	0.047	0.17		
1800	18×31.5	3635	0.021	0.057	560	16×40	2020	0.040	0.15		
2200	18×35.5	3680	0.017	0.046	680	18×35.5	1790	0.040	0.15		
2700	18×40	3800	0.014	0.038	820	18×40	2330	0.036	0.13		